



ACS USNCO  
U.S. National Chemistry Olympiad

# 2023 U.S. NATIONAL CHEMISTRY OLYMPIAD NATIONAL EXAM PART I

*Prepared by the American Chemical Society Chemistry Olympiad Examinations Task Force*

## OLYMPIAD EXAMINATIONS TASK FORCE

Seth N. Brown, **Chair**, *University of Notre Dame*, Notre Dame, IN

James Ayers, *Colorado Mesa University*, Grand Junction, CO  
Jerry Bell, *Simmons University*, Boston, MA (retired)  
Jesse Bernstein, *Miami Country Day School*, Miami, FL (retired)  
Mark DeCamp, *University of Michigan*, Dearborn, MI (retired)  
James Dohm, *ExxonMobil*, Houston, TX  
Xu Duan, *Holton-Arms School*, Bethesda, MD

Kimberly Gardner, *United States Air Force Academy*, CO  
Paul Groves, *South Pasadena HS*, South Pasadena, CA (retired)  
John Kotz, *State University of New York*, Oneonta, NY (retired)  
Sarah Leite, *Hopkins School*, New Haven, CT  
Michael A. Morgan, *Francisco Bravo Medical Magnet HS*, Los Angeles, CA  
Jane Nagurney, *Scranton Preparatory School*, Scranton, PA (retired)

### DIRECTIONS TO THE EXAMINER

The USNCO Subgroup is conducting a survey in an effort to determine the impact of the Olympiad program on students. At the end of the exam there are four questions, which should be answered on the same Scantron sheet students use for the exam. These questions may be administered after the 90 minutes allotted for the exam; each student should be encouraged to answer these questions.

**Part I** of this test is designed to be taken with a Scantron answer sheet on which the student records their responses. Only this Scantron sheet is graded for a score on Part I. Testing materials, scratch paper, and the Scantron sheet should be made available to the student *only* during the examination period. All testing materials including scratch paper should be turned in and kept secure until **April 23, 2023**, after which tests can be returned to students and their teachers for further study.

Allow time for students to read the directions, ask questions, and fill in the requested information on the Scantron sheet. The answer sheet must be completed using a pencil, not pen. When the student has completed **Part I**, or after **one hour and thirty minutes** has elapsed, the student must turn in the Scantron sheet, Part I of the testing materials, and all scratch paper.

There are three parts to the National Chemistry Olympiad Examination. You have the option of administering the three parts in any order, and you are free to schedule rest breaks between parts.

<b>Part I</b>	<b>60 questions</b>	<b>single answer, multiple-choice</b>	<b>1 hour, 30 minutes</b>
<b>Part II</b>	<b>8 questions</b>	<b>problem-solving, explanations</b>	<b>1 hour, 45 minutes</b>
<b>Part III</b>	<b>2 lab problems</b>	<b>laboratory practical</b>	<b>1 hour, 30 minutes</b>

A periodic table and other useful information are provided on page 2 for student reference.

**Students should be permitted to use non-programmable calculators. The use of a programmable calculator, cell phone, watch, or any other device that can access the internet or make copies or photographs during the exam is grounds for disqualification.**

### DIRECTIONS TO THE EXAMINEE – DO NOT TURN THE PAGE UNTIL DIRECTED TO DO SO.

Answers to questions in Part I must be entered on a Scantron answer sheet to be scored. Be sure to write your name and assigned ID number on the answer sheet. **Make a record of this ID number because you will use the same number on Parts II and III.** Each item in **Part I** consists of a question or an incomplete statement that is followed by four possible choices. Select the single choice that best answers the question or completes the statement. Then use a pencil to blacken the space on your answer sheet next to the same letter as your choice. You may write on the examination, but the test booklet will not be used for grading. Scores are based on the number of correct responses. When you complete **Part I** (or at the end of one hour and 30 minutes), you must turn in all testing materials, scratch paper, and your Scantron answer sheet.

**Do not forget to turn in your U.S. citizenship/Green Card Holder statement before leaving the testing site today.**

ABBREVIATIONS AND SYMBOLS					
amount of substance	<i>n</i>	Faraday constant	<i>F</i>	molar mass	<i>M</i>
ampere	A	free energy	<i>G</i>	mole	mol
atmosphere	atm	frequency	<i>v</i>	Planck's constant	<i>h</i>
atomic mass unit	u	gas constant	<i>R</i>	pressure	<i>P</i>
Avogadro constant	<i>N<sub>A</sub></i>	gram	g	rate constant	<i>k</i>
Celsius temperature	°C	hour	h	reaction quotient	<i>Q</i>
centi- prefix	c	joule	J	second	s
coulomb	C	kelvin	K	speed of light	<i>c</i>
density	d	kilo- prefix	k	temperature, K	<i>T</i>
electromotive force	<i>E</i>	liter	L	time	<i>t</i>
energy of activation	<i>E<sub>a</sub></i>	measure of pressure mm Hg		vapor pressure	VP
enthalpy	<i>H</i>	milli- prefix	m	volt	V
entropy	<i>S</i>	molal	<i>m</i>	volume	<i>V</i>
equilibrium constant	<i>K</i>	molar	M	year	y

CONSTANTS
$R = 8.314 \text{ J mol}^{-1} \text{ K}^{-1}$
$R = 0.08314 \text{ L bar mol}^{-1} \text{ K}^{-1}$
$F = 96,500 \text{ C mol}^{-1}$
$F = 96,500 \text{ J V}^{-1} \text{ mol}^{-1}$
$N_A = 6.022 \times 10^{23} \text{ mol}^{-1}$
$h = 6.626 \times 10^{-34} \text{ J s}$
$c = 2.998 \times 10^8 \text{ m s}^{-1}$
$0 \text{ }^\circ\text{C} = 273.15 \text{ K}$
1 atm = 1.013 bar = 760 mm Hg
Specific heat capacity of H <sub>2</sub> O = 4.184 J g <sup>-1</sup> K <sup>-1</sup>

EQUATIONS		
$E = E^\circ - \frac{RT}{nF} \ln Q$	$\ln K = \left( \frac{-\Delta H^\circ}{R} \right) \left( \frac{1}{T} \right) + \text{constant}$	$\ln \left( \frac{k_2}{k_1} \right) = \frac{E_a}{R} \left( \frac{1}{T_1} - \frac{1}{T_2} \right)$

## PERIODIC TABLE OF THE ELEMENTS

PERIODIC TABLE OF THE ELEMENTS																	
1																	18
1A																	8A
1 <b>H</b> 1.008	2 <b>He</b> 4.003															2 <b>He</b> 4.003	
3 <b>Li</b> 6.941	4 <b>Be</b> 9.012											5 <b>B</b> 10.81	6 <b>C</b> 12.01	7 <b>N</b> 14.01	8 <b>O</b> 16.00	9 <b>F</b> 19.00	10 <b>Ne</b> 20.18
11 <b>Na</b> 22.99	12 <b>Mg</b> 24.31	3 <b>B</b> 10.81	4 <b>C</b> 12.01	5 <b>N</b> 14.01	6 <b>O</b> 16.00	7 <b>F</b> 19.00	8 <b>Ne</b> 20.18	9 <b>Na</b> 22.99	10 <b>Mg</b> 24.31	11 <b>Al</b> 26.98	12 <b>Si</b> 28.09	13 <b>P</b> 30.97	14 <b>S</b> 32.07	15 <b>Cl</b> 35.45	16 <b>Ar</b> 39.95	17 <b>K</b> 39.10	18 <b>Ca</b> 40.08
19 <b>K</b> 39.10	20 <b>Ca</b> 40.08	21 <b>Sc</b> 44.96	22 <b>Ti</b> 47.88	23 <b>V</b> 50.94	24 <b>Cr</b> 52.00	25 <b>Mn</b> 54.94	26 <b>Fe</b> 55.85	27 <b>Co</b> 58.93	28 <b>Ni</b> 58.69	29 <b>Cu</b> 63.55	30 <b>Zn</b> 65.39	31 <b>Ga</b> 69.72	32 <b>Ge</b> 72.61	33 <b>As</b> 74.92	34 <b>Se</b> 78.97	35 <b>Br</b> 79.90	36 <b>Kr</b> 83.80
37 <b>Rb</b> 85.47	38 <b>Sr</b> 87.62	39 <b>Y</b> 88.91	40 <b>Zr</b> 91.22	41 <b>Nb</b> 92.91	42 <b>Mo</b> 95.95	43 <b>Tc</b> (98)	44 <b>Ru</b> 101.1	45 <b>Rh</b> 102.9	46 <b>Pd</b> 106.4	47 <b>Ag</b> 107.9	48 <b>Cd</b> 112.4	49 <b>In</b> 114.8	50 <b>Sn</b> 118.7	51 <b>Sb</b> 121.8	52 <b>Te</b> 127.6	53 <b>I</b> 126.9	54 <b>Xe</b> 131.3
55 <b>Cs</b> 132.9	56 <b>Ba</b> 137.3	57 <b>La</b> 138.9	72 <b>Hf</b> 178.5	73 <b>Ta</b> 180.9	74 <b>W</b> 183.8	75 <b>Re</b> 186.2	76 <b>Os</b> 190.2	77 <b>Ir</b> 192.2	78 <b>Pt</b> 195.1	79 <b>Au</b> 197.0	80 <b>Hg</b> 200.6	81 <b>Tl</b> 204.4	82 <b>Pb</b> 207.2	83 <b>Bi</b> 209.0	84 <b>Po</b> (209)	85 <b>At</b> (210)	86 <b>Rn</b> (222)
87 <b>Fr</b> (223)	88 <b>Ra</b> (226)	89 <b>Ac</b> (227)	104 <b>Rf</b> (261)	105 <b>Db</b> (262)	106 <b>Sg</b> (263)	107 <b>Bh</b> (262)	108 <b>Hs</b> (265)	109 <b>Mt</b> (266)	110 <b>Ds</b> (281)	111 <b>Rg</b> (272)	112 <b>Cn</b> (285)	113 <b>Nh</b> (286)	114 <b>Fl</b> (289)	115 <b>Mc</b> (289)	116 <b>Lv</b> (293)	117 <b>Ts</b> (294)	118 <b>Og</b> (294)

58 <b>Ce</b> 140.1	59 <b>Pr</b> 140.9	60 <b>Nd</b> 144.2	61 <b>Pm</b> (145)	62 <b>Sm</b> 150.4	63 <b>Eu</b> 152.0	64 <b>Gd</b> 157.3	65 <b>Tb</b> 158.9	66 <b>Dy</b> 162.5	67 <b>Ho</b> 164.9	68 <b>Er</b> 167.3	69 <b>Tm</b> 168.9	70 <b>Yb</b> 173.0	71 <b>Lu</b> 175.0
90 <b>Th</b> 232.0	91 <b>Pa</b> 231.0	92 <b>U</b> 238.0	93 <b>Np</b> (237)	94 <b>Pu</b> (244)	95 <b>Am</b> (243)	96 <b>Cm</b> (247)	97 <b>Bk</b> (247)	98 <b>Cf</b> (251)	99 <b>Es</b> (252)	100 <b>Fm</b> (257)	101 <b>Md</b> (258)	102 <b>No</b> (259)	103 <b>Lr</b> (262)

**DIRECTIONS**

- When you have selected your answer to each question, blacken the corresponding space on the answer sheet using a soft, #2 pencil. Make a heavy, full mark, but no stray marks. If you decide to change an answer, erase the unwanted mark very carefully.
- There is only one correct answer to each question. Any questions for which more than one response has been blackened **will not be counted**.
- Your score is based solely on the number of questions you answer correctly. **It is to your advantage to answer every question.**

1. An amino acid ( $M = 174$ ) with a formula of  $C_aH_bN_xO_2$  contains 8.1% by mass of H and 41.3% by mass of C. What is the value of  $x$  in its formula?

(A) 1      (B) 2      (C) 3      (D) 4

2. Potassium tris(oxalato)ferrate(III) trihydrate is prepared by precipitation from aqueous solution according to the following equation:

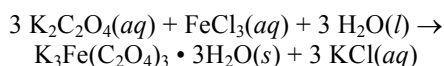

A student mixes 10.00 g  $\text{K}_2\text{C}_2\text{O}_4$  ( $M = 166.2$ ) and 5.00 g  $\text{FeCl}_3$  ( $M = 162.2$ ) in 20.0 mL water and isolates 5.74 g  $\text{K}_3\text{Fe}(\text{C}_2\text{O}_4)_3 \cdot 3\text{H}_2\text{O}$  by filtration. What is the percent yield of this reaction?

(A) 19.4%    (B) 37.9%    (C) 58.3%    (D) 65.5%

3. Carbon tetrachloride ( $\text{CCl}_4$ ,  $M = 153.8$ , density = 1.59 g  $\text{mL}^{-1}$ ) and heptane ( $\text{C}_7\text{H}_{16}$ ,  $M = 100.2$ , density = 0.68 g  $\text{mL}^{-1}$ ) are miscible liquids. Which solution has the highest concentration of  $\text{CCl}_4$ ?

- (A) 5% v/v  $\text{CCl}_4$  in heptane  
 (B) 5% w/w  $\text{CCl}_4$  in heptane  
 (C) 5 mol%  $\text{CCl}_4$  in heptane  
 (D) All three solutions have the same concentration of  $\text{CCl}_4$ .

4. A solution of 5.00 g of which substance dissolved in 100.0 g water has the highest boiling point?

(A)  $\text{H}_3\text{PO}_4$       (B)  $\text{H}_2\text{SO}_4$   
 (C)  $\text{H}_3\text{AsO}_4$     (D)  $\text{H}_2\text{SeO}_4$

5. A 1.802-g sample of a hydrated double salt containing two different metal ions with the formula of  $\text{M}_A(\text{M}_B)_2(\text{SO}_4)_4 \cdot 22\text{H}_2\text{O}$  is heated strongly to drive off all the water, leaving a residue of 1.000 g. What is the identity of  $\text{M}_A$ ?

(A) Ca      (B) Ti      (C) Fe      (D) Ba

6. Hypochlorite ion reacts with hydrogen peroxide to produce oxygen gas.

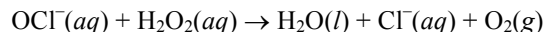

A series of experiments is carried out where 10.0 mL of a 0.30 M solution of hydrogen peroxide is mixed with a varying volume of 0.40 M sodium hypochlorite solution, and the oxygen gas evolved is collected over water. Which graph best represents how the volume of  $\text{O}_2$  varies with the volume of  $\text{NaOCl}$  solution used?

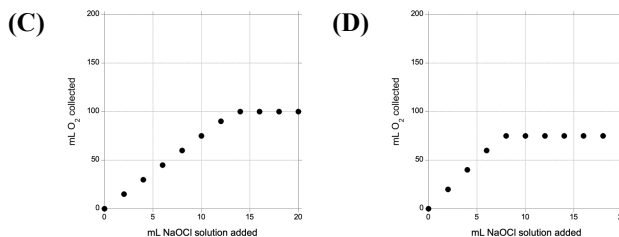
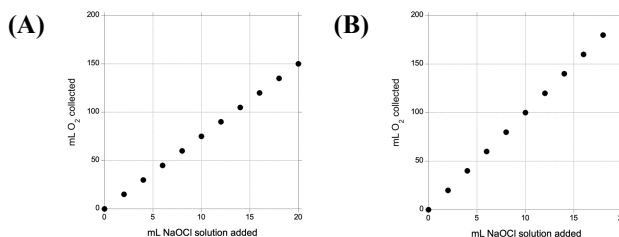

7. A weighed sample of iron ore is dissolved in 10 mL of 1.0 M hydrochloric acid and then titrated with 0.100 M  $\text{KMnO}_4$  to determine the percent iron by mass in the sample. Which glassware is the best choice for measuring the hydrochloric acid?

- (A) 50 mL buret  
 (B) 10 mL volumetric pipet  
 (C) 10 mL graduated pipet  
 (D) 10 mL graduated cylinder

8. A 0.1 M aqueous solution containing which metal ion is least intensely colored?

(A)  $\text{Cr}^{2+}$     (B)  $\text{Mn}^{2+}$     (C)  $\text{Co}^{2+}$     (D)  $\text{Ni}^{2+}$

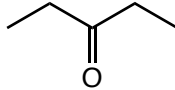
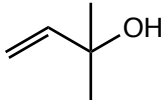
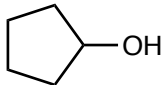
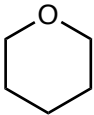
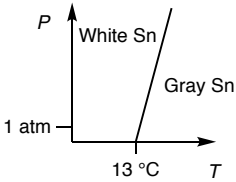
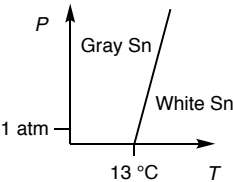
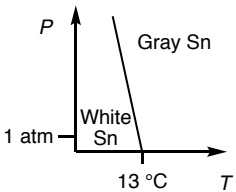
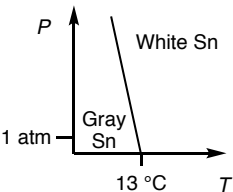
9. When equal volumes of a 1.0 M ammonium sulfate solution and a saturated solution of barium hydroxide are mixed, what is observed?
- Gas is evolved
  - A white precipitate forms.
- (A) I only                      (B) II only  
(C) Both I and II              (D) Neither I nor II
10. A weighed sample of a copper-nickel alloy is dissolved in a known volume of nitric acid. Which method is most suitable for determining the mass percent of copper in the alloy?
- Treatment of an aliquot of the solution with excess iodide, followed by titration of the iodine produced with sodium thiosulfate.
  - Measurement of the absorbance of the solution at a wavelength of light at which both  $\text{Cu}^{2+}$  and  $\text{Ni}^{2+}$  absorb, and comparison with the absorbances of known standards of the two ions.
  - Addition of excess sodium hydroxide to the solution, isolation of the metal hydroxides by filtration, and measurement of the mass of the precipitate.
  - Bubbling hydrogen gas through the solution and measuring the mass of the metal that precipitates from the solution.
11. Which metal ion forms the least soluble perchlorate salt?
- (A)  $\text{Li}^+$     (B)  $\text{Mg}^{2+}$     (C)  $\text{K}^+$     (D)  $\text{Ca}^{2+}$
12. A sample of malachite,  $\text{Cu}_2\text{CO}_3(\text{OH})_2$ , is heated over a Bunsen burner to form  $\text{CuO}$ . The mass percent copper in the sample is calculated based on the mass before and after heating. Which could explain the experimentally determined percent copper being lower than that expected for malachite?
- The sample is not heated as strongly as recommended in the procedure (not long or hot enough).
  - The sample is heated more strongly than recommended in the procedure (too long or too hot).
  - Azurite ( $\text{Cu}_3(\text{CO}_3)_2(\text{OH})_2$ ) is present in the sample.
  - Goethite ( $\text{FeO}(\text{OH})$ ) is present in the sample.
13. A bicycle tire is filled with air to a pressure of 72 psi at a temperature of  $25.0^\circ\text{C}$ . If the air temperature inside the tire increases to  $55.0^\circ\text{C}$ , and the volume of the tire increases by 5.0%, what is the pressure inside the tire?
- (A) 69 psi                      (B) 75 psi  
(C) 83 psi                      (D) 166 psi
14. Which  $\text{C}_5\text{H}_{10}\text{O}$  isomer has the highest normal boiling point?
- (A)               (B)   
(C)               (D) 
15. Two substances Q and R have the same normal boiling point. Substance Q has a larger enthalpy of vaporization than substance R. Which is true about the relative boiling points of the substances at 2.0 atm pressure?
- The boiling point of Q is lower than the boiling point of R at 2.0 atm.
  - The boiling points of Q and R are the same at 2.0 atm.
  - The boiling point of Q is higher than the boiling point of R at 2.0 atm.
  - The relative boiling points cannot be predicted from the information given.
16. The density of white tin is  $7.28\text{ g cm}^{-3}$  and the density of gray tin is  $4.75\text{ g cm}^{-3}$ . The conversion of white tin to gray tin,  $\text{Sn}(s, \text{white}) \rightarrow \text{Sn}(s, \text{gray})$ , has a standard enthalpy of reaction of  $-2.1\text{ kJ mol}^{-1}$  at 298 K. At 1 atm pressure, white tin and gray tin are in equilibrium at  $13^\circ\text{C}$ . Which best represents the phase diagram of tin near  $13^\circ\text{C}$  and 1 atm?
- (A)               (B)   
(C)               (D) 
17. Nickel crystallizes in a face-centered cubic structure. The edge of a unit cell has a length of 352 pm. What is the distance between the nuclei of two adjacent nickel atoms in this lattice?
- (A) 117 pm                      (B) 176 pm  
(C) 249 pm                      (D) 305 pm

18. A 10-gram sample of a substance is added to a rigid evacuated 1 L vessel. The pressure in the vessel is measured as a function of temperature and the following graph is obtained:

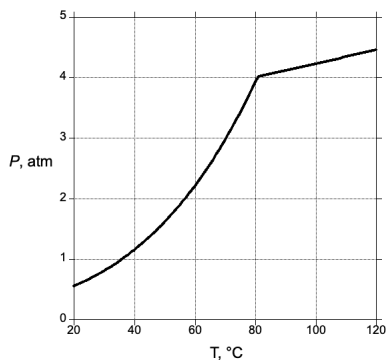

Which graph is obtained if a 10-gram sample of the substance is heated in a 2 L vessel?

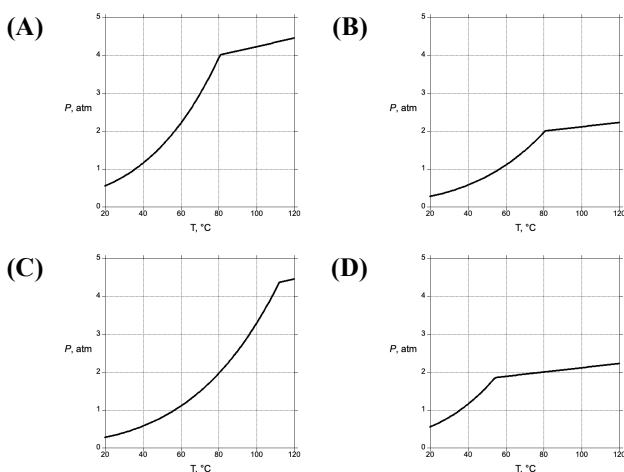

19. The phase change

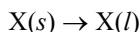

has  $\Delta G^\circ > 0$  at 300 K. Which statement about this reaction must be correct?

- (A)  $K_{\text{eq}} < 1$  at 300 K  
 (B)  $\Delta S^\circ < 0$  at 300 K  
 (C) Liquid X cannot exist at 300 K  
 (D) The melting point of X is greater than 300 K
20. For which reaction is  $\Delta H^\circ_{\text{rxn}}$  closest to  $\Delta G^\circ_{\text{rxn}}$ ?

- (A)  $2 \text{CO}_2(g) \rightarrow 2 \text{CO}(g) + \text{O}_2(g)$   
 (B)  $2 \text{HCl}(g) \rightarrow \text{H}_2(g) + \text{Cl}_2(g)$   
 (C)  $2 \text{H}_2\text{O}(l) \rightarrow 2 \text{H}_2(g) + \text{O}_2(g)$   
 (D)  $2 \text{NaCl}(s) \rightarrow 2 \text{Na}(s) + \text{Cl}_2(g)$

21. 2.00 g solid iodine, initially at 300 K, is heated in a sealed vessel maintained at 1.00 atm pressure. The temperature of the sample as a function of the amount of heat added to it is shown below.

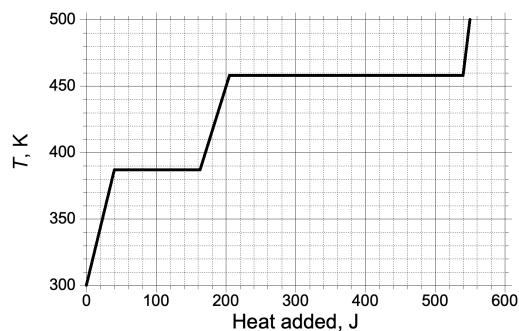

What is the entropy of vaporization of  $\text{I}_2$ ,  $\Delta S^\circ_{\text{vap}}$ , at its normal boiling point?

- (A)  $40.1 \text{ J mol}^{-1} \text{ K}^{-1}$       (B)  $52.6 \text{ J mol}^{-1} \text{ K}^{-1}$   
 (C)  $56.8 \text{ J mol}^{-1} \text{ K}^{-1}$       (D)  $92.8 \text{ J mol}^{-1} \text{ K}^{-1}$
22. 20.0 mL of  $\text{NaOH}(aq)$  is titrated against 1.00 M  $\text{HCl}(aq)$  in a well-insulated vessel with constant stirring. Each solution is initially at  $22.0^\circ \text{C}$ , and the temperature of the reaction mixture is monitored after each 2.0 mL of hydrochloric acid is added. What is  $\Delta H^\circ$  for the reaction that takes place? Assume that all solutions' densities and heat capacities are the same as that of pure water, and that solution volumes are additive.

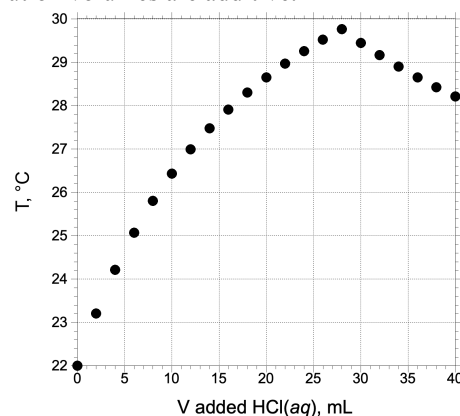

- (A)  $-15 \text{ kJ mol}^{-1}$       (B)  $-31 \text{ kJ mol}^{-1}$   
 (C)  $-39 \text{ kJ mol}^{-1}$       (D)  $-54 \text{ kJ mol}^{-1}$
23. Silver ion reacts with ammonia to form a complex ion:

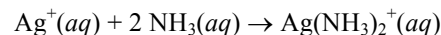

In a certain solution at equilibrium at 298 K,  $[\text{Ag}^+] = [\text{NH}_3] = [\text{Ag}(\text{NH}_3)_2^+] = C$ . What is  $\Delta G_{\text{rxn}}$  at 298 K if  $[\text{Ag}^+] = [\text{NH}_3] = [\text{Ag}(\text{NH}_3)_2^+] = 0.1C$ ?

- (A)  $-5.7 \text{ kJ mol}^{-1}$       (B)  $0 \text{ kJ mol}^{-1}$   
 (C)  $5.7 \text{ kJ mol}^{-1}$       (D)  $11.4 \text{ kJ mol}^{-1}$

24. Equal volumes of 1.00 M  $\text{HSO}_4^-(aq)$  and 1.00 M  $\text{SO}_4^{2-}(aq)$  are mixed. The pH of this solution varies with the reciprocal of the absolute temperature as shown.

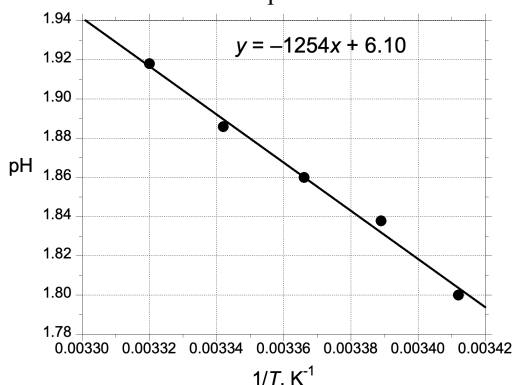

What is the standard enthalpy change for the acid dissociation of  $\text{HSO}_4^-(aq)$ ?

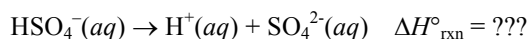

- (A)  $-24.0 \text{ kJ mol}^{-1}$       (B)  $-10.4 \text{ kJ mol}^{-1}$   
 (C)  $10.4 \text{ kJ mol}^{-1}$       (D)  $24.0 \text{ kJ mol}^{-1}$
25. Hydroxide ion reacts with methyl iodide to give methanol in an irreversible second-order reaction with a rate constant  $k = 6.5 \times 10^{-5} \text{ L mol}^{-1} \text{ s}^{-1}$ .

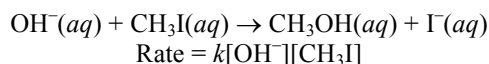

How long will it take the concentration of  $\text{CH}_3\text{I}$  to decrease from 0.010 M to 0.0020 M in a 1.00 M solution of sodium hydroxide?

- (A) 120 s      (B)  $2.5 \times 10^4 \text{ s}$   
 (C)  $4.1 \times 10^6 \text{ s}$       (D)  $6.2 \times 10^6 \text{ s}$
26. The temperature-dependence of the rate constant of a chemical reaction can be described by the Arrhenius equation,  $k = Ae^{-E_a/RT}$ . Which elementary chemical reaction has the largest Arrhenius pre-factor  $A$ ?
- (A)  $(\text{CH}_3)_3\text{CBr}(aq) \rightarrow (\text{CH}_3)_3\text{C}^+(aq) + \text{Br}^-(aq)$   
 (B)  $\text{N}_2\text{O}_4(g) \rightarrow 2 \text{NO}_2(g)$   
 (C)  $\text{CH}_3\text{NC}(g) \rightarrow \text{CH}_3\text{CN}(g)$   
 (D)  $(\text{CH}_3\text{O})_2\text{SO}_2(aq) + \text{OH}^-(aq) \rightarrow \text{CH}_3\text{OH}(aq) + \text{CH}_3\text{OSO}_3^-(aq)$

27. The iodination of acetone is irreversible and has a rate law of  $\text{Rate} = k[\text{CH}_3\text{COCH}_3][\text{H}^+]$ .

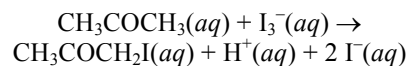

When the reaction is carried out with an initial concentration of  $\text{I}_3^-$  much smaller than those of either acetone or  $\text{H}^+$ , it is observed that the yellow color due to  $\text{I}_3^-$  fades over time, finally disappearing abruptly at a time  $t$ . How does  $t$  depend on the initial concentrations?

	Dependence on: $[\text{CH}_3\text{COCH}_3]$	$[\text{H}^+]$	$[\text{I}_3^-]$
(A)	Direct	Direct	None
(B)	Inverse	Inverse	None
(C)	Direct	Direct	Inverse
(D)	Inverse	Inverse	Direct

28. The reaction between A and B is carried out twice, with  $[\text{A}]_0 = 0.50 \text{ M}$  in each run but with two different initial concentrations of B, and the results are shown below. What can be concluded about the rate law?

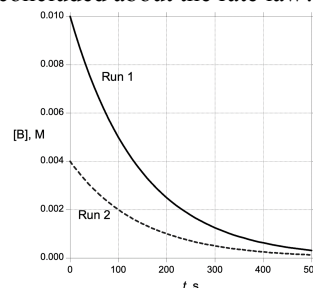

- (A)  $\text{Rate} = (0.0069 \text{ s}^{-1})[\text{B}]$   
 (B)  $\text{Rate} = (0.0069 \text{ M}^{-1} \text{ s}^{-1})[\text{A}][\text{B}]$   
 (C)  $\text{Rate} = (0.014 \text{ M}^{-1} \text{ s}^{-1})[\text{A}][\text{B}]$   
 (D) The reaction is first order in B, but the order in A cannot be determined from the available data.
29. Nitrogen dioxide reacts with carbon monoxide with the rate law shown

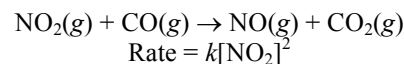

Which mechanisms are consistent with this rate law?

- I.  $2 \text{NO}_2 \rightleftharpoons \text{N}_2\text{O}_4$       *fast, unfavorable*  
 $\text{N}_2\text{O}_4 + \text{CO} \rightarrow \text{N}_2\text{O}_3 + \text{CO}_2$       *slow*  
 $\text{N}_2\text{O}_3 \rightarrow \text{NO} + \text{NO}_2$       *fast*
- II.  $2 \text{NO}_2 \rightarrow \text{NO} + \text{NO}_3$       *slow*  
 $\text{NO}_3 + \text{CO} \rightarrow \text{NO}_2 + \text{CO}_2$       *fast*
- (A) I only      (B) II only  
 (C) Both I and II      (D) Neither I nor II

30. The reaction coordinate diagram of a reaction that takes place at 300 K is shown below.

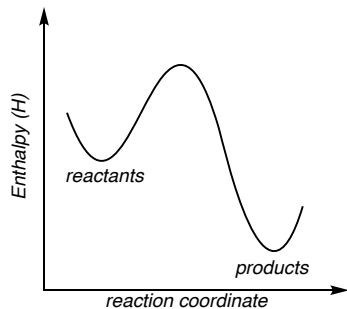

Which best represents the reaction coordinate diagram for the same reaction at 340 K?

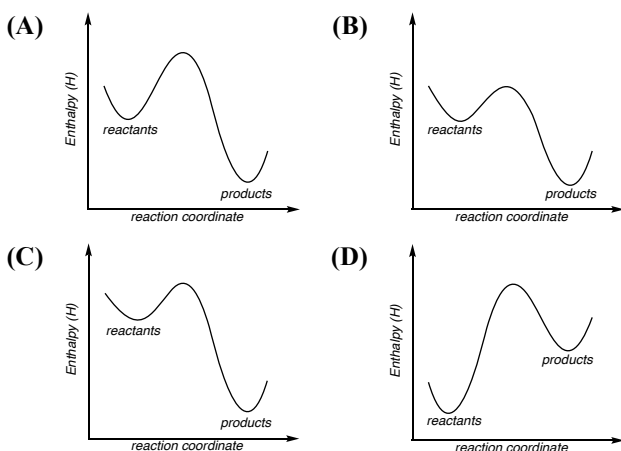

31. Pure  $\text{PCl}_5$  is placed in a rigid flask so that its pressure at  $250^\circ\text{C}$  is 2.000 bar. The gas slowly decomposes to  $\text{PCl}_3$  and  $\text{Cl}_2$  at this temperature, and the partial pressure of  $\text{Cl}_2$  is eventually 0.814 bar. What is the value of  $K_p$  for the reaction?

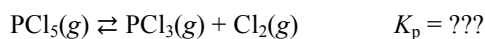

- (A) 0.559    (B) 0.686    (C) 0.814    (D) 1.78
32. What is the maximum concentration of lead(II) ions at equilibrium in a solution with  $\text{pH} = 10.50$ ? The  $K_{\text{sp}}$  of  $\text{Pb}(\text{OH})_2$  is  $1.4 \times 10^{-15}$ .
- (A)  $7.1 \times 10^{-6} \text{ M}$     (B)  $1.4 \times 10^{-8} \text{ M}$   
 (C)  $3.5 \times 10^{-9} \text{ M}$     (D)  $4.4 \times 10^{-12} \text{ M}$
33. The  $\text{p}K_{\text{a}}$  of methylammonium ion,  $\text{CH}_3\text{NH}_3^+$ , is 10.64. What is the percent ionization of a 0.20 M solution of methylamine,  $\text{CH}_3\text{NH}_2$ ?
- (A) 0.0011%    (B) 0.071%  
 (C) 1.1%    (D) 4.7%

34. Which statement best describes the differences between a 0.1 M solution of ammonium bicarbonate,  $\text{NH}_4(\text{HCO}_3)$ , and a 0.1 M solution of ammonium carbonate,  $(\text{NH}_4)_2\text{CO}_3$ ?

- (A) The pH of the ammonium bicarbonate solution is lower because bicarbonate is a weaker base than carbonate.  
 (B) The pH of the ammonium bicarbonate solution is lower because both ammonium ion and bicarbonate ion can act as Brønsted acids.  
 (C) The pH of the ammonium bicarbonate solution is higher because it has only half the ammonium ion concentration of the ammonium carbonate solution.  
 (D) The pH of the ammonium bicarbonate solution is higher because it contains only two-thirds as many total ions as the ammonium carbonate solution.

35. A mixture of  $\text{N}_2\text{O}_4(\text{g})$  and  $\text{NO}_2(\text{g})$  is contained in a vessel whose total volume can change but where the total pressure is maintained at 1.00 atm. The initial temperature is 298 K, and the two gases are in equilibrium. Which changes will result in an increase in the number of moles of  $\text{NO}_2$  present at equilibrium?



- I. Adding  $\text{Ne}(\text{g})$   
 II. Increasing the temperature to 310 K
- (A) I only    (B) II only  
 (C) Both I and II    (D) Neither I nor II

36. Silver iodide is a sparingly soluble salt. Silver also forms a soluble complex ion,  $\text{AgI}_2^-$ , with iodide ion. A series of solutions saturated with solid  $\text{AgI}$  and containing various concentrations of dissolved iodide ion are prepared, and the total concentration of silver dissolved in each solution is measured. Which graph of the logarithm of the total silver concentration as a function of the logarithm of the iodide concentration best represents the results of this experiment?

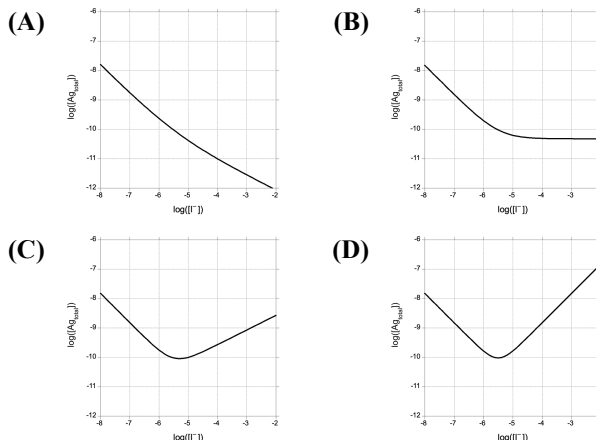

37. Which species has the largest coefficient when the chemical equation for the disproportionation of white phosphorus in basic solution is balanced?

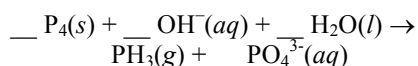

- (A)  $\text{P}_4(s)$  (B)  $\text{OH}^-(aq)$   
 (C)  $\text{H}_2\text{O}(l)$  (D)  $\text{PH}_3(g)$
38. Which reagent would spontaneously reduce  $\text{Fe}^{2+}(aq)$  to  $\text{Fe}(s)$  under standard conditions?
- (A)  $\text{H}_2(g)$  (B)  $\text{Ni}(s)$   
 (C)  $\text{Sn}^{2+}(aq)$  (D)  $\text{Zn}(s)$
39. In a test of the selectivity of an electrocatalyst for the reduction of carbon dioxide to methanol, electrolysis is carried out with a constant current of 0.370 A for 155 minutes. Afterwards, the cathodic compartment of the cell is analyzed and is found to contain  $5.30 \times 10^{-3}$  mol  $\text{CH}_3\text{OH}$ . What is the faradaic yield (the percent yield based on the current passed through the cell)?
- (A) 14.8% (B) 29.7% (C) 59.4% (D) 89.2%
40. The cathodic compartment of an electrolytic cell is 0.100 M in the ions  $\text{Fe}(\text{CN})_6^{3-}$  and  $\text{Cu}^{2+}$  and has a chemically inert electrode. As current is passed through the cell, which best describes how  $\text{Cu}(s)$  is deposited on the electrode?

Half-reaction	$E^\circ, \text{V}$
$\text{Cu}^{2+}(aq) + 2e^- \rightarrow \text{Cu}(s)$	+0.337
$\text{Fe}(\text{CN})_6^{3-} + e^- \rightarrow \text{Fe}(\text{CN})_6^{4-}$	+0.370

- (A) Copper is deposited immediately, but at a rate much lower than 1 mol per 193000 C. As the electrolysis proceeds, the rate of copper deposition increases.
- (B) Copper is deposited immediately, at a rate close to 1 mol per 193000 C. As the electrolysis proceeds, the rate of copper deposition decreases.
- (C) No copper is deposited for a certain length of time, then copper deposition begins.
- (D) Copper is deposited at a rate of 1 mol per 193000 C for a certain length of time, then the rate of copper deposition decreases.

41. What is  $E^\circ$  for the disproportionation of hydrogen manganate ion in acidic solution?

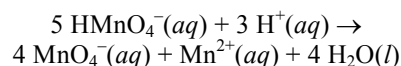

Half-reaction	$E^\circ, \text{V}$
$\text{MnO}_4^-(aq) + \text{H}^+(aq) + e^- \rightarrow \text{HMnO}_4^-(aq)$	+0.90
$\text{MnO}_4^-(aq) + 8 \text{H}^+(aq) + 5 e^- \rightarrow \text{Mn}^{2+}(aq) + 4 \text{H}_2\text{O}(l)$	+1.51

- (A) 0.61 V (B) 0.76 V (C) 0.99 V (D) 1.21 V
42. In the galvanic cell shown, the silver electrode is oxidized to  $\text{Ag}^+$  while  $\text{AuCl}_4^-$  is reduced to elemental Au, and the measured cell potential is 0.13 V.

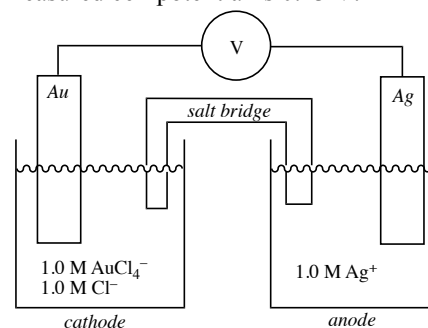

Which change will result in the largest value of the measured cell potential?

- (A) The concentration of  $\text{AuCl}_4^-$  is decreased to 0.10 M.  
 (B) The concentration of  $\text{Cl}^-$  is decreased to 0.10 M.  
 (C) The concentration of  $\text{Ag}^+$  is decreased to 0.10 M.  
 (D) The surface area of the Ag electrode is decreased by a factor of 10.
43. One electron in a ground-state gas-phase Ge atom has quantum numbers ( $n, l, m_l, m_s$ ) of (4, 1, 1,  $-\frac{1}{2}$ ). Which of the following cannot be a valid set of quantum numbers for another electron in this atom?
- (A) (3, 2, 1,  $\frac{1}{2}$ ) (B) (4, 0, 0,  $-\frac{1}{2}$ )  
 (C) (4, 1, 0,  $\frac{1}{2}$ ) (D) (4, 1, -1,  $-\frac{1}{2}$ )
44. How many nodes does the radial wave function of a 3s orbital have?
- (A) 0 (B) 1 (C) 2 (D) 3
45. Which transition in a gas-phase hydrogen atom would absorb the most energy?
- (A)  $n = 1 \rightarrow n = 3$  (B)  $n = 2 \rightarrow n = 4$   
 (C)  $n = 3 \rightarrow n = 1$  (D)  $n = 4 \rightarrow n = 2$

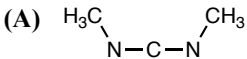
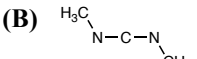
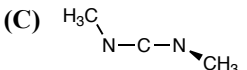
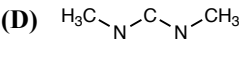
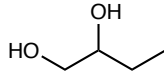
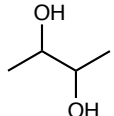
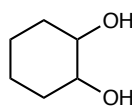
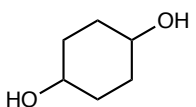
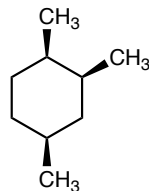

46. Which element has a gas-phase electron affinity closest to that of sulfur (S)?  
 (A) O (B) P (C) Cl (D) Se
47. The first ionization energy of gallium (Ga, 578.8 kJ mol<sup>-1</sup>) is greater than that of aluminum (Al, 577.5 kJ mol<sup>-1</sup>). Which is the best explanation for this?  
 (A) The 3*d* electrons in gallium imperfectly screen the nuclear charge from the outermost electrons.  
 (B) The 4*p* orbitals in gallium have an additional radial node compared to the 3*p* orbitals in aluminum and thus have more electron density very close to the nucleus.  
 (C) Gallium has a half-filled subshell, which is unusually stable.  
 (D) Because electron energy is proportional to 1/*n*<sup>2</sup>, electrons with higher principal quantum numbers have lower energies and hence are more difficult to ionize.
48. By what mode does the isotope <sup>31</sup>S undergo radioactive decay?  
 (A) Alpha decay (B) Beta decay  
 (C) Gamma decay (D) Positron emission
49. Which species has the longest carbon-oxygen bond?  
 (A) HCO<sub>2</sub><sup>-</sup> (B) CO<sub>3</sub><sup>2-</sup> (C) CO<sub>2</sub> (D) COS
50. Which molecule has a dipole moment of zero?  
 (A) BCl<sub>3</sub> (B) NI<sub>3</sub> (C) AsH<sub>3</sub> (D) BrF<sub>3</sub>
51. Which ions are linear?  
 I. NO<sub>2</sub><sup>+</sup>  
 II. ICl<sub>2</sub><sup>-</sup>  
 (A) I only (B) II only  
 (C) Both I and II (D) Neither I nor II
52. Which is the best description of the structure of the substance whose empirical formula is NPF<sub>10</sub>?  
 (A) F<sub>5</sub>N-PF<sub>5</sub> (B) F<sub>3</sub>N-PF<sub>7</sub>  
 (C) [NF<sub>4</sub>][PF<sub>6</sub>] (D) [PF<sub>4</sub>][NF<sub>6</sub>]
53. Which is the best representation of the three-dimensional arrangement of the atoms in dimethyl carbodiimide, CH<sub>3</sub>NCNCH<sub>3</sub>?  
 (A)  (B)   
 (C)  (D) 
54. Two substances with the formula (en)<sub>2</sub>CoCl<sub>3</sub> (en = ethylenediamine, H<sub>2</sub>NCH<sub>2</sub>CH<sub>2</sub>NH<sub>2</sub>) have different aqueous solubilities and different UV-visible spectra in aqueous solution. Which is the most likely explanation for this observation?  
 (A) The substances are enantiomers.  
 (B) The substances are geometric isomers.  
 (C) One substance contains [(en)<sub>2</sub>CoCl<sub>2</sub>]Cl with six-coordinate cobalt and the other contains (en)<sub>2</sub>CoCl<sub>3</sub> molecules with seven-coordinate cobalt.  
 (D) One substance contains [(en)<sub>2</sub>CoCl<sub>2</sub>]Cl with six-coordinate cobalt and the other contains [(en)<sub>2</sub>Co]Cl<sub>3</sub> with four-coordinate cobalt.
55. Which molecule is achiral in all of its stereoisomeric forms?  
 (A)  (B)   
 (C)  (D) 
56. How many methyl groups are axial in the most stable chair conformation of the trimethylcyclohexane shown below?  
  
 (A) Zero (B) One (C) Two (D) Three
57. Which series lists the carboxylic acid derivatives in increasing order of reactivity in hydrolysis reactions?  
 (A) CH<sub>3</sub>CH<sub>2</sub>CONH<sub>2</sub> < CH<sub>3</sub>CH<sub>2</sub>COOCH<sub>3</sub> < CH<sub>3</sub>CH<sub>2</sub>COCl  
 (B) CH<sub>3</sub>CH<sub>2</sub>COOCH<sub>3</sub> < CH<sub>3</sub>CH<sub>2</sub>CONH<sub>2</sub> < CH<sub>3</sub>CH<sub>2</sub>COCl  
 (C) CH<sub>3</sub>CH<sub>2</sub>CONH<sub>2</sub> < CH<sub>3</sub>CH<sub>2</sub>COCl < CH<sub>3</sub>CH<sub>2</sub>COOCH<sub>3</sub>  
 (D) CH<sub>3</sub>CH<sub>2</sub>COOCH<sub>3</sub> < CH<sub>3</sub>CH<sub>2</sub>COCl < CH<sub>3</sub>CH<sub>2</sub>CONH<sub>2</sub>

58. Which  $C_6H_{10}$  isomer has the most positive standard enthalpy of formation?

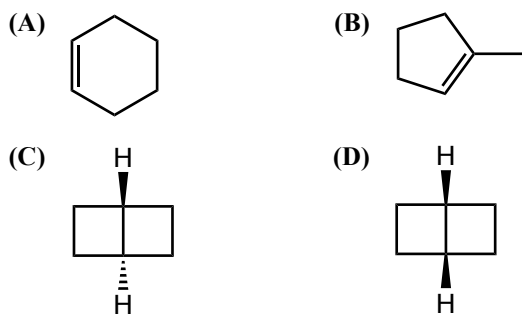

59. Which reagent reacts readily with butanal ( $CH_3CH_2CH_2CHO$ ), but not with 2-pentanone ( $CH_3CH_2CH_2COCH_3$ )?

- (A)  $K_2Cr_2O_7$  in aqueous  $H_2SO_4$   
(B)  $I_2$  in aqueous  $NaOH$   
(C)  $CH_3MgBr$  in  $Et_2O$   
(D)  $NaBH_4$  in  $CH_3OH$

60.  $\alpha$ -D-glucose and  $\beta$ -D-glucose interconvert in aqueous solution at pH 7 (mutarotation). Which best describes the intermediate in this isomerization?

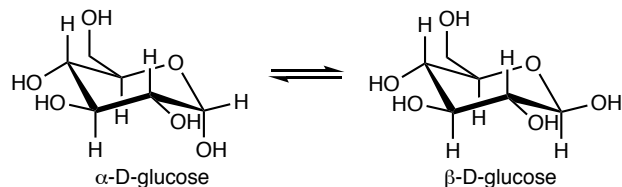

- (A) A planar oxacyclohexane  
(B) An acyclic aldohexose  
(C) A disaccharide  
(D) An achiral glycoside

61. The amount of time I spend doing experiments in the laboratory per week on average during my chemistry course was/is?

- (A) less than  $\frac{1}{2}$  hour  
(B) between  $\frac{1}{2}$  and 1 hour  
(C) between 1 and 2 hours  
(D) more than 2 hours

The following questions should be answered using the scale

- (A) Strongly agree  
(B) Agree  
(C) Disagree  
(D) Strongly disagree

62. As a result of my participation in the USNCO program, I plan to study more chemistry.

63. As a result of my participation in the USNCO program, I plan to major in chemistry in college.

64. As a result of my participation in the USNCO program, I have a more positive view of chemistry than I did before participating.

---

**END OF TEST**

---

---

**PLEASE ANSWER THE FOLLOWING  
FOUR QUESTIONS**

---

**THANK YOU!**

---

When you have finished answering this examination or time has been called by the Examiner, please provide responses to the following 4 items. Your answers will not affect your score on the exam but will help with a study being conducted by the U.S. National Chemistry Olympiad (USNCO) Subgroup.

---

---

**Olympiad 2023**  
**USNCO National Exam**  
**KEY**

<b>Number</b>	<b>Correct Answer</b>	<b>% Correct Answers</b>	<b>Number</b>	<b>Correct Answer</b>	<b>% Correct Answers</b>
1.	D	81%	31.	A	67%
2.	C	52%	32.	B	57%
3.	A	41%	33.	D	38%
4.	B	47%	34.	A	38%
5.	C	78%	35.	C	27%
6.	D	35%	36.	D	23%
7.	D	36%	37.	B	63%
8.	B	42%	38.	D	53%
9.	B	29%	39.	D	28%
10.	A	9%	40.	C	22%
11.	C	18%	41.	B	9%
12.	C	72%	42.	B	27%
13.	B	37%	43.	C	37%
14.	C	29%	44.	C	62%
15.	A	37%	45.	A	69%
16.	D	54%	46.	D	35%
17.	C	16%	47.	A	48%
18.	D	27%	48.	D	43%
19.	D	79%	49.	B	53%
20.	B	41%	50.	A	72%
21.	D	40%	51.	C	42%
22.	D	35%	52.	C	45%
23.	D	24%	53.	C	31%
24.	A	42%	54.	B	23%
25.	B	31%	55.	D	48%
26.	B	31%	56.	B	30%
27.	D	31%	57.	A	25%
28.	D	58%	58.	C	20%
29.	B	76%	59.	A	37%
30.	A	35%	60.	B	33%